

OVERALL ASSEMBLY DIMENSIONS:

EXTERNAL - 145 x 170.4 x 68.2

INTERNAL - 133 x 164.6 x 63.8

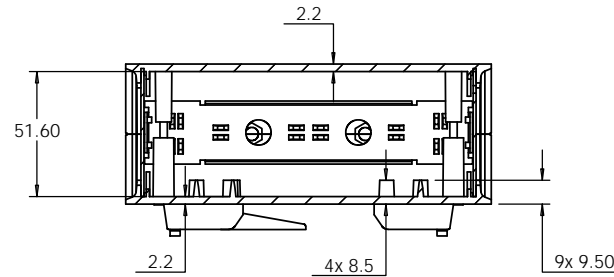
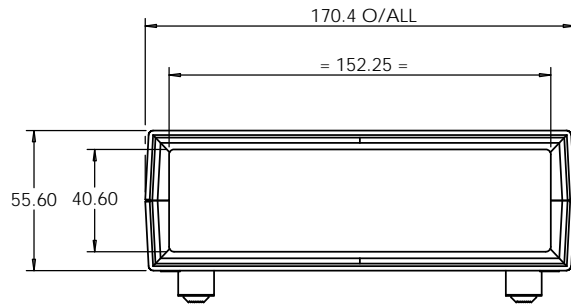

COMPLETE ASSEMBLY

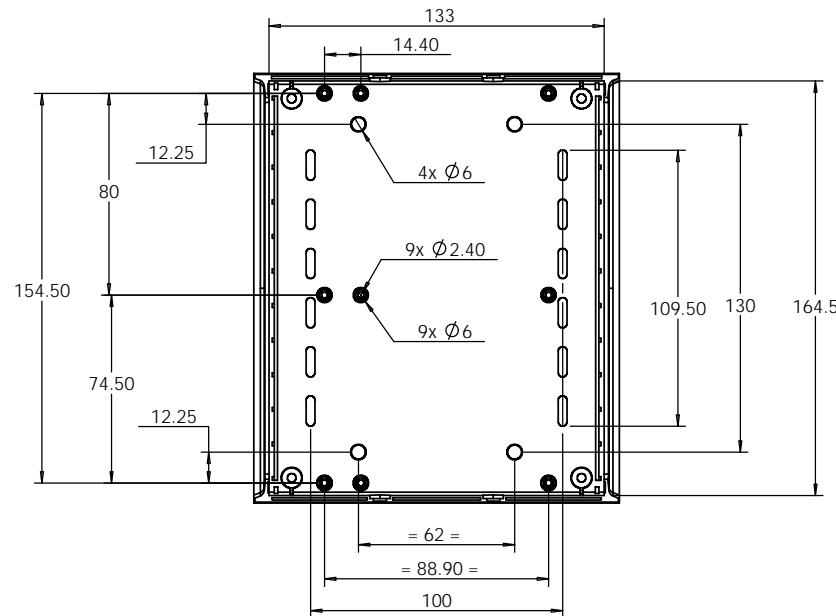
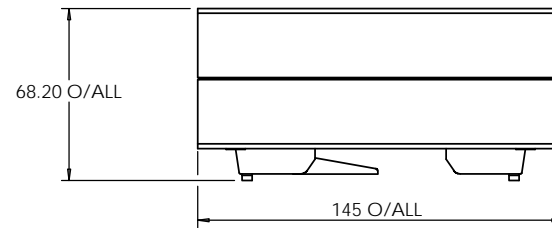
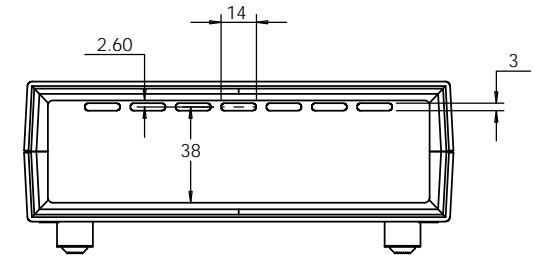

BASE ONLY

UNIT ELEVATION ANGLE 0° or 16°

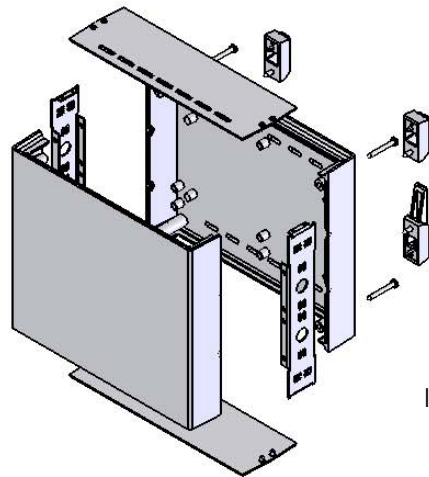

ISO VIEW
1:5

		UNLESS OTHERWISE SPECIFIED: DIMENSIONS ARE IN MILLIMETERS		DO NOT SCALE DRAWING	REVISION. 0
		FINISH: ---		TITLE: ASSEMBLY DRG FOR 3502 EURO CONSOLE	
JAMES CARTER RD, MILDENHALL, SUFFOLK. IP28 7DE TEL: 01638 716101 FAX: 01638 716554 EMAIL: SALES@BOSS-ENCLOSURES.CO.UK WEB: www.BOSS-ENCLOSURES.CO.UK		MATERIAL.	VAR	DWG NO.	3502
DRAWN	S.HARDINGE	SIGNED	SJH	DATE	28/03/08
CHK'D	-	-	-	-	-
PROJECTION.				SCALE: 1:3	SHEET 1 OF 1
				A4	